



GC Valves LLC

A DEMA Company

SPECIALISTS IN FLUID CONTROL

VALVE SELECTION INFORMATION & ENGINEERING GUIDE



How To Select A Solenoid Valve

We offer a wide variety of General Purpose Solenoid Valves from which to choose. To select the valve that best suits your application, determine the following:

Valve Type and Operating Mode

Available configurations include:

2-Way Normally Closed - Two pipe connections (inlet and outlet) and one orifice to provide On-Off control. Valve is open when energized, closed when de-energized.

2-Way Normally Open - Two pipe connections (inlet and outlet) and one orifice to provide On-Off control. Valve is closed when energized, open when de-energized.

3-Way Normally Closed - Three pipe connections (one always open to one of the other two) and two orifices (one always open and one always closed) to regulate the direction of media flow. When energized, the flow is from the inlet port through the cylinder port; When de-energized, the flow is from the cylinder port through the exhaust port.

3-Way Normally Open - Three pipe connections (one always open to one of the other two) and two orifices (one always open and one always closed) to regulate the direction of media flow. When de-energized, the flow is from the inlet port through the cylinder port. When energized, the flow is from the cylinder port through the exhaust port.

3-Way Universal, Diverting & Selecting - Three pipe connections (one always open to one of the other two) and two orifices (one always open and one always closed) to regulate the direction of media flow. Valves can be installed to provide either normally closed (open when energized, closed when de-energized) or normally open (closed when energized, open when de-energized) operation. The valve can also be connected to select one of two flow media or to divert media flow from one port to another.

Pipe Connections

Pipe connections (ports) are openings that conduct the flow of the controlled media in and out of the valve. Factors influencing the selection of pipe sizes are the system's existing or designed pipe connection sizes and the flow requirements (Cv) of the application.

Cv Factor

Cv is the amount of water at standard conditions (60°F,

specific gravity = 1) in GPM (gallons per minute) which will pass through the valve with a one psi (pound per square inch) pressure drop across the valve in the full open position. The appropriate Cv will determine which combination of pipe and orifice sizes will be required for the application. Refer to the "VALVE SIZING" and "Cv Factor" sections for additional information.

Operating Temperature

Sealing materials, coil class, body materials, and duty cycle all influence the valve's temperature capabilities. Operating temperature is determined by a combination of media and ambient temperatures.

Flow Media

Flow media is the substance being controlled by the valve. The media's temperature, pressure, and concentration will determine the type of body and sealing materials required for the application.

Power Requirements









































Voltage and Cycles (Hertz) will usually be determined by the system's existing power specifications. VA is a measure of the solenoid's power consumption. The "inrush" VA rating is the maximum initial surge of current required to energize the coil, while "holding" VA is a lesser current required to hold the valve in its energized position. In either case, the solenoid's amperage is determined by dividing the VA rating by the applied voltage. Inrush and holding currents are identical for DC solenoids, and the rating is given in watts (watts DC = volts x amperes).

Minimum Operating Pressure Differential

The minimum system pressure differential required to operate the valve and maintain it in the open position. MinOPD applies pilot-operated solenoid valves where system pressure is used assist operation when the solenoid is energized. Direct acting or zero differential valves do not require a minimum operating pressure.



Maximum Operating Pressure Differential



The maximum operating pressure differential is the maximum difference in pressure (measured in psi or bar) between the inlet and the outlet valve ports. Factors influencing the maximum operating pressure rating include the pipe connection sizes, orifice size(s), and design of construction.

Series	Media	Connection	Function	Orifice Range	Pressure Range	Max Fluid Temp	Cv Range	Approvals	Valve Body	Seal Materials
 S20		3/8"-1 1/2" NPT	NC, NO	5/8"-1 1/4"	0-200 PSI	295 ° F	4.3-23			Nitrile, FKM, GFLT, EPDM
 S21		3/8"-2" NPT	NC, NO	5/8"-1 1/2"	4-250 PSI	366 ° F	4.3-29			Nitrile, FKM, GFLT, EPDM
 S27		1"-2" NPT	NC, NO	1"-1 1/4"	0-125 PSI	295 ° F	13-27			Nitrile, FKM, GFLT, EPDM
 SC91		10/32"-1/4" NPT	NC, NO	0.8mm-3.0mm	0-580 PSI	266 ° F	0.035-0.280			Nitrile, FKM, EPDM, PTFE, FFKM
 SC31		1/8"-1/4" NPT	NC, NO	0.8mm-3.0mm	0-580 PSI	122 ° F	0.035-0.280			Nitrile, FKM, EPDM, PTFE, FFKM
 SC41		1/4"-3/8" NPT	NC, NO	0.8mm-6.0mm	0-2030 PSI	284 ° F	0.035-0.350			Nitrile, FKM, EPDM, PTFE, FFKM
 S30		1/8"-3/8" NPT	NC, NO, 3-way	1/32"-3/8"	0-2400 PSI	366 ° F	.03-1.3			Nitrile, FKM, GFLT, EPDM, PTFE, FFKM, Rulon
 S31		1/8"-3/8" NPT	NC, NO, 3-way	1/32"-3/8"	0-2000 PSI	366 ° F	.03-1.3			Nitrile, FKM, GFLT, EPDM, PTFE, FFKM, Rulon
 S33		1/8"-1/4" NPT	3-way	1/16"-11/64"	0-200 PSI	295 ° F	.09-.38			Nitrile, FKM, EPDM
 S40		1/4"-1 1/4" NPT	NC, NO	3/8"-1 1/8"	0-300 PSI	366 ° F	1.1-18.8			Nitrile, FKM, EPDM, PTFE

KEY

MEDIA





-  Water
-  Air & neutral gases
-  Light Oil

-  Slightly Aggressive media
-  Aggressive media
-  Steam

FUNCTION

- NC – 2-way Normally Closed
- NO – 2-way Normally Open
- 3-way – Normally Closed, Normally Open, Diverting, Universal, or Free Exhaust







VALVE BODY

-  Brass
-  Nylon
-  316 Stainless Steel
-  PVC
-  304 Stainless Steel
-  Lead-Free Brass

Series	Media	Connection	Function	Orifice Range	Pressure Range	Max Fluid Temp	Cv Range	Approvals	Valve Body	Seal Materials
 S71		3/8"-2" NPT	NC, NO	3/8"-2"	7-225 PSI	295 ° F	4.5-48			Nitrile, FKM, EPDM
 S80		1/4"-1/2" NPT	NC, NO	3/8"	0-290 PSI	230 ° F	1.6			Nitrile, FKM
 SP31		3/8"-2" NPT	NC, NO	12mm-55mm	5-150 PSI	122 ° F	2.4 - 41			Nitrile, FKM, EPDM
 SP91		1/2"-1" NPT	NC, NO	4.0mm-25mm	8-200 PSI	266 ° F	4.5 - 12			Nitrile, FKM, EPDM
 H40		1/4"-1/2" NPT	NC, NO	3/8"	0-2200 PSI	230 ° F	1 - 1.5			FKM, PTFE
 H90		1/2"-1" NPT	NC	15mm-25mm	0-1200 PSI	230 ° F	4.2-7			FKM, PTFE
 NS20		3/8"-1 1/2" NPT	NC, NO	5/8"-1 1/4"	0-100 PSI	295 ° F	4.3-18			EPDM, Santoprene
 NS21		3/8"- 2" NPT	NC, NO	5/8"-1 1/4"	4-200 PSI	295 ° F	4.3-13			EPDM, Santoprene
 NS30		1/8"-3/8" NPT	NC, NO	1/32"-9/32"	0-150 PSI	295 ° F	.03-1			EPDM
 NS31		1/8"-3/8" NPT	NC, NO	1/32"-9/32"	0-150 PSI	366 ° F	.03-.65			EPDM
 NS71		3/8"- 2" NPT	NC, NO	3/8"-2"	7-225 PSI	295 ° F	4.5-48			EPDM

KEY







MEDIA

-  Water
-  Air & neutral gases
-  Light Oil
-  Slightly Aggressive media
-  Aggressive media
-  Steam

FUNCTION

- NC – 2-way Normally Closed
- NO – 2-way Normally Open
- 3-way – Normally Closed, Normally Open, Diverting, Universal, or Free Exhaust

VALVE BODY

-  Brass
-  Nylon
-  316 Stainless Steel
-  PVC
-  304 Stainless Steel
-  Lead-Free Brass



The following information is transcribed from the requirements of **NEMA** and the **American Institute of Electrical Engineers** covering various classifications of the Underwriters' Laboratories. These requirements are listed for reference purposes only. They are taken from the requirements of the approval associations or engineering groups. They are not necessarily an indication of what should be sold in the way of control apparatus. GC Valves does not supply all types of enclosures on all valves designs. (Contact GC Valves Customer Service for specific combinations.)

NEMA Enclosure Types

In non-hazardous locations, the specific enclosure types, their applications, and the environmental conditions they are designed to protect against, when completely and properly installed, are as follows:

Type 1 - Enclosures constructed for indoor use to provide a degree of protection to personnel against incidental contact with the enclosed equipment and to provide a degree of protection against falling dirt.

Type 4 - Enclosures constructed for either indoor or outdoor use to provide a degree of protection against incidental contact with the enclosed equipment; to provide a degree of protection against falling dirt, rain, sleet, snow, windblown dust, splashing water, and hose-directed water; and that will be undamaged by the external formation of ice on the enclosure.

Type 4X - Enclosures constructed for either indoor or outdoor use to provide a degree of protection against incidental contact with the enclosed equipment; to provide a degree of protection against falling dirt, rain, sleet, snow, windblown dust, splashing water, hose-directed water, and corrosion; and that will be undamaged by the external formation of ice on the enclosure.

NEMA 7 & 9 Refers to Indoor Hazardous Locations - Air-break Equipment

Class I Refers to locations in which flammable gases or vapors are or may be present in the air in quantities sufficient to produce explosive or ignitable mixtures.

Group C - Acetaldehyde, Cyclopropane, Diethyl Ether, Ethylene, Isoprene, & Unsymmetrical Dimethyl

Group D - A wide range of gases and vapors including gasoline, propane, natural gas, methanol, acetone, butane, benzene, octanes, toluene, and xylenes

Class II Refers to locations which are hazardous because of the presence of combustible dust.

Group E - Atmospheres containing combustible metal dust

Group F - Atmospheres containing carbon black, coal or coke dust

Group G - Atmospheres containing flour, starch, or grain dust

Class I and **Class II** also have the following designations:

Division 1 refers to hazardous gases or dust that exist continuously

Division 2 refers to hazardous gases or dust that do not normally exist but may exist due to equipment failure etc.





Our explosion proof housings are not approved for:

"Group A" Acetylene



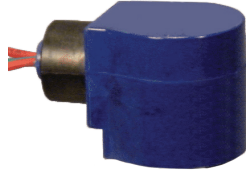
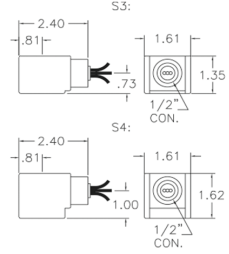

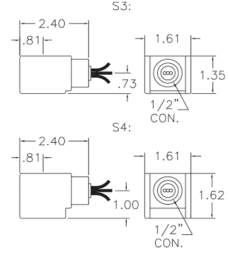
"Group B" Butadiene, Ethylene Oxide, Hydrogen, Gases containing more than 30% Hydrogen, and Propylene Oxide.

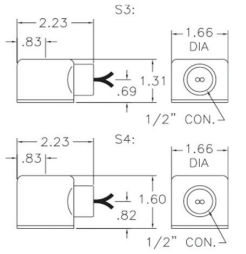
Housing Codes

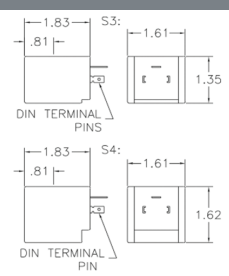

Conduit - Coil Family S3 & S4

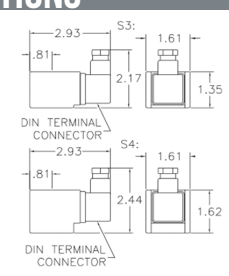
G	A	W
 	 	 
<p>NEMA 4/4X; Fully encapsulated, 24 inch lead wires, 1/2" conduit hub</p>	<p>NEMA 1; Metallic housing, 24 inch lead wires, 1/2" conduit hub</p>	<p>NEMA 1; Rain-Tight Metallic housing, 24 inch lead wires, 1/2" conduit hub</p>

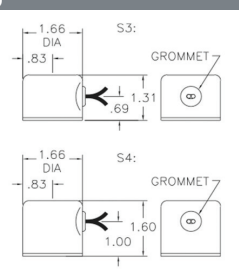
DIN - Coil Family S3 & S4



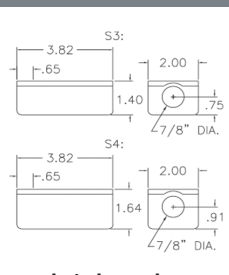

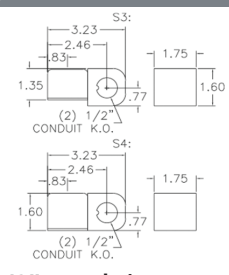
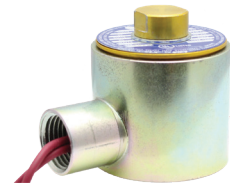
Y	DIN OPTIONS	B
 	 	 
<p>ISO; Fully encapsulated, spade terminal, European configuration, NEMA 4</p>	<p>ISO; Molded connectors, cables, timers etc. designed for DIN coil/housing</p>	<p>Metallic housing, 24 inch lead wires</p>

Junction Box - Coil Family S3 & S4

S	U	X
 	 	
<p>Standard - with 1/2" conduit knockout, lead wires</p>	<p>Compact with two 1/2" conduit knockouts, lead wires</p>	<p>Explosion Proof; 24 inch lead wires, 1/2" conduit hub Class I & II Groups C, D, E, F & G, Division 1 & 2</p>

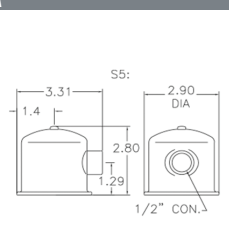
**Contact
GC Valves
Customer
Service
for
dimensions.**

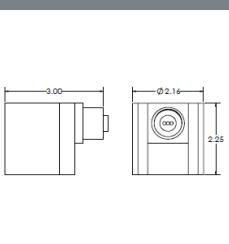
Conduit - Coil Family S5

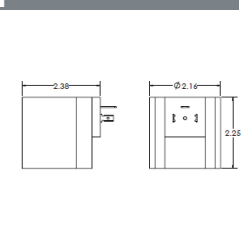
A	G	Y
 	 	 
<p>NEMA 1; Metallic housing, 24 inch lead wires, 1/2" conduit hub</p>	<p>NEMA 1; Plastic housing, 24 inch lead wires, 1/2" conduit hub</p>	<p>Fully encapsulated form A, NEMA 4 with connector</p>

Seal Material & Shading Ring Codes

Code	Seal	Shading Ring	Code	Seal	Shading Ring	Code	Seal	Shading Ring
C	EPR	Copper	L	Viton	Silver	T (S21)	Teflon/EPR	Copper
E	EPR	Silver	N	Nitrile	Copper	T (H40)	Teflon/Viton	Copper
J	Nitrile	Silver	R	Rulon	Silver	V	Viton	Copper
K	Teflon	Silver	S	Teflon	Copper			
K (S21)	Viton	Copper	T	Teflon	Copper			

Voltage Codes

Code	Voltage
01	24 VAC/60Hz
02	120 VAC/60Hz 110 VAC/50Hz
03	208 VAC/60Hz
04	240 VAC/60Hz 220 VAC/50Hz
07	480 VAC/60Hz 440 VAC/50Hz

Code	Voltage
14	6 VDC
15	12 VDC
16	24 VDC
17	32 VDC
18	120 VDC

Code	Voltage
24	24 VAC/50-60Hz
33	48 VDC
54	240 VAC/50Hz
55	380 VAC/50Hz
74	74 VDC

** For Additional Variations Contact GC Valves Customer Service.*

Valve Sizing & Cv Flow Factor

Valve Sizing Procedures

The successful operation of a controlled system depends on proper sizing of the valve.

The Cv rating of any valve is the flow rate of water at standard conditions (60°F, specific gravity = 1) in GPM (gallons per minute), which will pass through the valve with a one psi (pound per square inch) pressure drop across the valve when in the fully open position. This rating is determined by the manufacturer's tests and is published in catalogs and specification sheets.

A valve so restricted or ported which passes 1 GPM of liquid with a specific gravity of 1 and an accompanying pressure drop of 1 psi is assigned a rating of Cv = 1. By comparison, a valve having a Cv = 2 would have twice the flow capacity with the same pressure drop.

Please contact GC Valves Customer Service for assistance in determining the required flow factor for your application.



VALVE SERIES	OPERATING MODE	COIL HOUSING	COIL CLASS	COIL VOLTAGE	SEAT SHADING RING	BODY MATERIAL	PIPE SIZE	2-WAY ORIFICE*	SUFFIX
S20	1 - 2W NC	A - Metal Conduit	F	01 - 24V/60HZ	A - FFKM Silver	1 - 316 SS	A - 1/8"	C1 - 1/32"	A - Angle Body
S21	2 - 2W NO	B - Grommet	H	02 - 110VAC/50HZ	C - EPDM Copper	2 - 303 SS	B - 1/4"	C3 - 3/64"	B - SS Split Washer
S27	3 - 3W NC	F - DIN w/ C-4010		120VAC/60HZ	E - EPDM Silver	3 - 303 SS	C - 3/8"	C5 - 1/16"	C - CE Declaration
S30	4 - 3W NO	G - 1/2" Conduit		03 - 208V/60HZ	F - EPDM + Sant	4 - Brass	D - 1/2"	C7 - 5/64"	D - Mounting Bracket
S31	5 - Selector	NEMA 4X		04 - 240V/60HZ	Copper	5 - Brass	E - 3/4"	C9 - 3/32"	E - CSA Certification
S33	6 - 3W	P - Open Frame with		220V/50HZ	G - GFLT Silver	6 - Aluminum	F - 1"	D3 - 7/64"	F - Metering
S40	Universal	Leads		24 - 24VAC/50-60HZ	J - Nitrile Silver	7 - 316 SS	G - 1-1/4"	D5 - 1/8"	G - Gold Plated Plunger
S71	7 - 3W FREE	S - Long Junction BOX		14 - 6V DC	K - FKM Copper (S21)	8 - Brass	H - 1-1/2"	D7 - 5/32"	and Tube Head
H21	Exhaust	U - Rain Tight Metal		15 - 12V DC	K - PTFE Silver	9 - Brass	J - 2"	E1 - 3/16"	K - Mounting Bracket
H40		Conduit		16 - 24V DC	(S30, S31,S40)	P - Nylon		E7 - 1/4"	L - Latching
M20		W - Rain Tight Metal		18 - 120V DC	L - FKM Silver			F1 - 9/32"	M - Manual Override
M21		Conduit		33 - 48V DC	N - Nitrile Copper			F5 - 3/8"	N - Cleaned for Oxygen
NS20		X - Explosion Proof		45 - 12V DC	R - Rulon Silver			G1 - 1/2"	Service
NS21		NEMA 7/9		14 Watt	S - PTFE Copper			G4 - 5/8"	NP - Gaseous CO2
NS30		Y - DIN		46 - 24V DC	T - PTFE Copper			G5 - 3/4"	P - Nickel Plating
NS31				14 Watt	V - FKM Copper			G7 - 15/16"	S - UL Safety Rated
NS71				74 - 74V DC	Z - PTFE + FKM Copper			G9 - 1"	T - TimeSaver Conn
								J1 - 1-1/8"	W - Submersible
								J2 - 1-1/4"	Z1 - 48" Coil Leads
								J5 - 1-1/2"	Z2 - 36" Coil Leads
								10 - 10mm	Z5 - Liquid CO2

K13 refer to catalog or price list

Contact GC Valves to verify model numbers and feature compatibility

* 3-way orifices refer to catalog or price list

DECADES OF INNOVATION & EXCELLENCE

GC Valves heritage has its roots in the founding of General Controls back in the 1930's. Through targeted acquisitions and partnerships, what started out as one company and one product line over 80 years ago is now a globally recognized and trusted brand covering dozens of markets and hundreds of applications. Despite our growth, we never lost focus of what's core to our business – our dedication to understanding our customers' needs and providing an exceptional experience. These values are what make us the trusted provider for solenoid valves and solutions to some of the most respected names in their respective industries. In its current form as GC Valves, LLC, it's the combination of two industry leading organizations, Components for Automation (Simi Valley, CA) and GC Valves (Charlotte, NC) under the DEMA Engineering Company umbrella.

GC Valves designs and manufactures world class solenoid valves to meet the requirements of a wide variety of markets and applications. Whether you're in a car wash, food manufacturing plant or medical facility, you'll likely find a GC Valves solenoid valve in operation. Variations are available to handle virtually any liquid or gas from vacuum to high flow / pressure; cryogenics to steam; natural gas to fuel oil; air and water to reagents and enzymes; ultra-pure to corrosive. Our versatile range of products can include pipe sizes from 10-32 to 2 inch in single valve, manifold, explosion proof and intrinsically safe designs. Our extensive design and development experience has contributed to a product catalog of over 35,000 solenoid valve variations. If we don't have what you need readily available, our design and development team will work with you to create a product that meets your requirements.



456 Crompton Street
Charlotte, NC 28273

Tel: 800-828-0484

gcvlves.com

sales@GCValves.com